

200 SERIES - INLINE DUCT BLOWERS
OPERATION INSTRUCTIONS AND PARTS MANUAL
MODELS: 207, 209, 210, 212, 215, 218

General Safety

Rotating parts, (pulleys, shafts and belts) on fans should not be exposed. Where these components are not protected by ductwork, cabinets or covers, appropriate guards should be employed to restrict exposure to rotating parts. Access doors should not be opened with the fan operating to avoid foreign objects being drawn into the system. On initial start-up, a careful inspection should be carried out to ensure no foreign material is present which could become airborne in the system.

Read installation and operation instructions carefully before attempting to install, operate or service Delhi 200 Series Blowers. Failure to comply with instructions could result in personal injury and/or property damage. Retain instructions for future reference



Model	Max. H.P.	Shaft Dia.	Weight
207	3/4	3/4"	43
209	3/4	3/4"	55
210	1-1/2	3/4"	65
212	1-1/2	3/4"	82
215	3	1"	140
218	5	1"	158

General

Inspect unit for damage, report any shipping damage to carrier. Check all fasteners, re-tighten as required.. Rotate the blower wheel by hand to ensure free rotation. If rubbing occurs, loosen the set screw(s), re-position the wheel to the shaft center, re-tighten set screws.

Installation

Suspension Mounting

Suspend the unit using 4 threaded rods through the (4) 7/8" clearance holes located at the top of the unit (see Fig. 1) or by an angle iron cradle (supplied by others) under the unit.

Base Mounting

Secure unit through the 4 internal 7/8" clearance holes to a solid base. Ensure unit is level. Complete installation of inlet & outlet ducts.

Flexible inlet & outlet duct collars are recommended to minimize vibration transmission

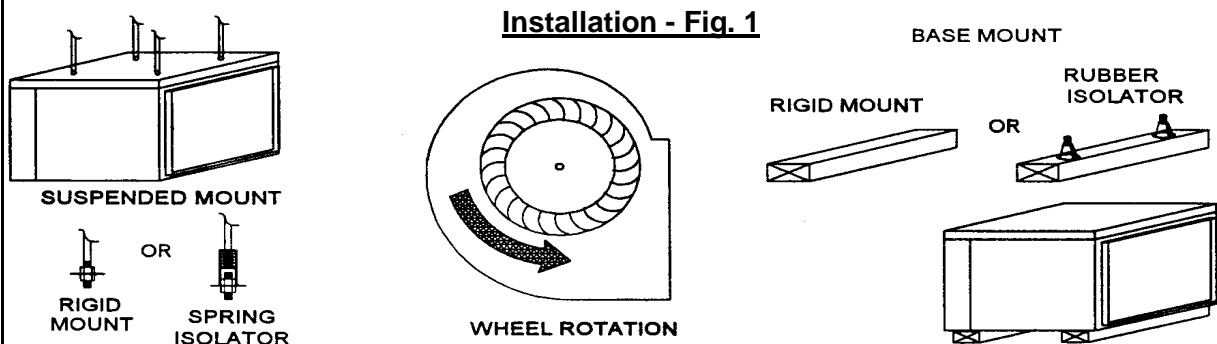

Motor, Pulleys & Belts (See table pg. 3)

1. Mount the blower pulley on the blower shaft and tighten the set screw securely on the key of the shaft.
2. Mount the motor pulley on the motor shaft. Leave some clearance between the pulley and the motor end bell. Tighten the set screws on the key of the motor shaft.
3. Install the motor on the motor platform using the hardware provided.
4. With the platform in its minimum position, install the V-belt within the pulley grooves. Position the motor on the motor platform to ensure proper pulley alignment (see Fig. 2) and secure to the motor platform. (A straight edge across the face of the driven pulley should be parallel to the belt once proper alignment has been achieved).

Note: Adjustments in the variable speed pulley require pulley re-alignment.

5. Pivot the motor platform to tension the V-belt and lock in place using the 2 bolts on both sides of the blower. (Ideal belt tension is the lowest tension at which the belt will not slip during start up. A rule of thumb suggests that 3/4" of deflection mid-span under medium finger pressure (2-3 lbs.) for every foot of span is appropriate.)

Warning

EXCESSIVE BELT TENSION IS THE MOST FREQUENT CAUSE OF BEARING WEAR AND RESULTING NOISE. PROPER BELT TENSION IS CRITICAL FOR QUIET EFFICIENT OPERATION

Ideal belt tension is the lowest value under which belt slip will not occur at peak load conditions.

Belt Alignment - Fig. 2



Bearing Replacement - Fig. 3

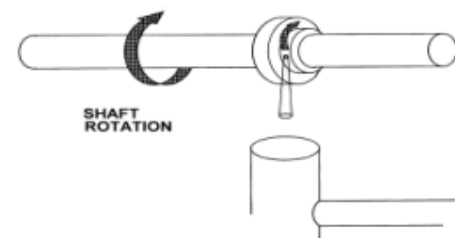

Electrical

Warning: Ensure power supply is disconnected & locked out prior to making electrical connections.

Before connecting the motor to the electrical supply, check the electrical characteristics and wiring instructions as indicated on the motor nameplate or inside the conduit box cover to ensure proper voltage and phase. Complete electrical connections as indicated.

Warning: A ground wire must be connected from the motor housing to a suitable electrical ground.

Operation

1. Complete the electrical connections, energize the unit momentarily and ensure proper wheel rotation. (see Fig. 1).
2. Apply full power.
3. With all ducts attached, the access doors in place and the air system in full operation, measure the motor current and ensure that it is less than the rated full load motor amperage as indicated on the motor nameplate.

Drive Table			Model					
			207	209	210	212	215	218
Max. HP			3/4	3/4	1-1/2	1-1/2	3	5
Motor Pulley	Blower Pulley	RPM Range	48 FRAME	48 FRAME	56T/143T & 145T FRAME	56T/143T & 145T FRAME	56T/143T & 1455T FRAME	182T/184T FRAME
IVL34 & 1VP34 3/4 HP MAX.	12	278-424	--	---	---	--	--	--
	10	335-511	--	---	---	4L530	4L570	--
	9	373-569	--	---	4L480	4L510	4L550	--
	8	421-642	--	4L430	4L460	4L490	4L530	--
	7	483-737	4L370	4L410	4L440	4L480	4L510	--
	6	567-865	4L360	4L390	4L420	4L450	4L490	--
	5	685-1046	4L340	4L370	4L400	4L440	4L470	--
	4	862-1316	4L310	4L360	4L390	4L420	4L450	--
3	1170-1786	4L290	4L340	4L360	4L400	--	--	
IVL34 & 1VP34	BK160H	168-333	--	--	--	--	B66	IVL34 & 1VP34 not available 1-1/8" bore
	BK140H	308-384	--	--	--	--	B61	
	BK130H	333-416	--	--	--	B56	B59	
	BK120H	363-454	--	--	--	B54	B57	
	BK110H	398-500	--	--	B48	B52	B55	
	BK100H	440-555	--	--	B46	B50	B53	
	BK90H	492-625	4L400	4L430	B44	B48	B51	
	BK80H	559-714	4L380	4L410	B42	B46	B50	
	BK70H	646-833	4L360	4L400	B40	B44	B48	
	BK60H	766-1000	4L340	4L380	B39	B43	B46	
	BK50H	940-1230	4L320	4L360	B37	B41	B45	
BK40H	1150-1553	4L310	4L350	B36	B39	--		
IVP44	BK130H	431-546	--	--	--	B57	B60	B65
	BK120H	469-595	--	--	B51	B55	B58	B63
	BK110H	514-655	--	4L480	B49	B53	B56	B62
	BK100H	568-728	--	4L460	B47	B51	B54	B60
	BK90H	636-819	4L410	4L440	B45	B49	B53	B58
	BK80H	722-936	4L390	4L430	B44	B47	B51	B56
	BK70H	835-1092	4L370	4L410	B42	B46	B49	B54
	BK60H	990-1309	4L350	4L390	B40	B44	B48	--
	BK50H	1215-1607	4L330	4L370	B38	B41	--	--
	BK40H	1509-2048	4L310	--	--	--	--	--

Maintenance

Warning: Ensure power supply is disconnected and locked out prior to performing maintenance.

1. Inspect and tighten all bearing collar and wheel set screws after the first 50 to 100 hours of operation and periodically thereafter.
2. Follow motor manufacturer's instructions for motor lubrication. Remove any excess lubrication.
3. Check the drives.
 - a. Tighten set screws on pulleys, wheel and bearing locking collars.
 - b. Check belt tension and alignment.
 - c. Replace cracked or worn belts.
4. Blower bearings are permanently lubricated and require no further lubrication.
5. Inspect V-belts for wear and proper tension. If it is necessary to replace one belt on a multiple belt drive, replace all the belts with a matched set. Do not use belt dressing.
6. Clean the blower wheel periodically. Material build up on the blades can cause wheel imbalance which may result in wheel or bearing failure.
7. To reinstall replacement ball bearings press the locking collar against the inner ring of the bearing and turn in the direction of the shaft rotation until engaged. Insert a drift pin into the pin hole and tap lightly to set. Tighten set screw on locking collar firmly (see Fig. 3).
8. Should further service to the blower be necessary, refer to the exploded view illustration (see Fig. 4).

200 Series Replacement Parts / Exploded View - Fig. 4

Parts List

1. Cabinet
2. Access Door
3. Housing
4. Wheel
5. Baffle
6. Bearing Bracket
7. Ball Bearing Assembly
8. Base Side
9. Shaft
10. Motor Platform
11. Rubber Grommet
12. 1/4"x20 Self Tapping Screw
13. 5/16"x18 HX Bolt

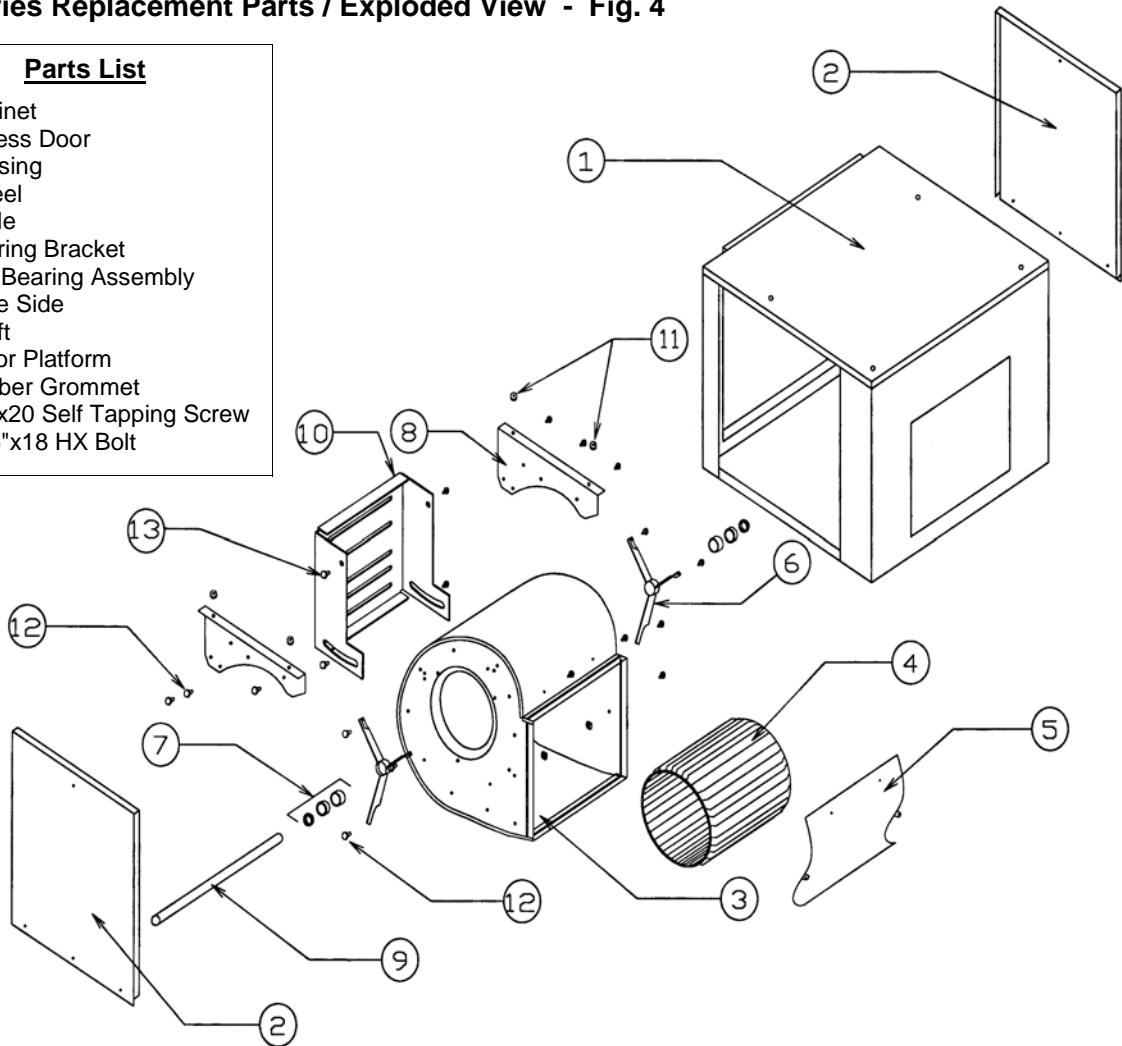

Warranty

Delhi Industries Inc. Air Moving Products are guaranteed for a period of one year against manufacturing defects in material and workmanship when operating under normal conditions. Liability is limited to the replacement of defective parts. Labour and transportation costs are not included.

Delhi Industries Inc
523 James Street
Delhi, Ontario
Canada N4B 2Z3

Tel: (519) 582-2440
Fax . (519) 582-0581
www.delhi-industries.com